

# CZ LOKO

*Locomotion Excellence®*



# CATALOG

LOCOMOTIVES AND SPECIAL VEHICLES

---

---

# THE FUTURE OF CZ LOKO

„The future of CZ LOKO lies in providing comprehensive services directly at our clients site with a focus on strengthening export activities.”

Josef Gulyás  
Managing Director  
and Vice Chairman of the Board



## CZ LOKO

*Locomotion Excellence®*

---

# VISION

---

Our goal is to increase safety, reliability and efficiency of vehicles, which are the source of railway transportation, through innovative and available solutions.

# HISTORY

---

The history of CZ LOKO dates back to 1849 when the operation of workshops for repairing steam locomotives and rolling stock was started in the town of Česká Třebová. Today CZ LOKO is a major European manufacturer of locomotives and special rolling stock with a wide range of products and services.



# MISSION

---

CZ LOKO is a reliable and perspective partner of railway carriers in the field of production, modernisation, repairs, leasing and servicing of powered and special vehicles.

---

# OUR OWN WAY

The brand of CZ LOKO means its own know-how in the field of production, modernisation and repairs of powered and special rolling stock. Complex technical facilities, flexible approach to; the needs of our business partners and efficient management of work processes. Professional vehicle care, collection of operational data and their systematic evaluation increase the efficiency of customer investments.

---

## DESIGN AND PRODUCTION OF NEW DIESEL LOCOMOTIVES



---

## MODERNIZATION OF LOCOMOTIVES AND SPECIAL VEHICLES



---

## LEASE OF LOCOMOTIVES, SERVICING AND MAINTENANCE OF ROLLING STOCK



---

## REPAIRS OF LOCOMOTIVES AND SPECIAL VEHICLES





NEW CONSTRUCTION



new diesel engine



GENERAL OVERHAUL



original diesel engine

new diesel engine



COMPLEX MODERNISATION



new diesel engine



SPECIAL PROJECTS



new diesel engine

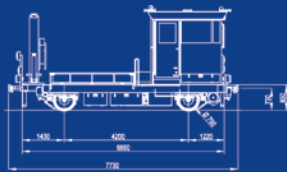

NEW CONSTRUCTION / MODERNISATION



new diesel engine



## WE DESIGN YOUR COMPLEX SOLUTION





# REFERENCE

CZ LOKO is and will continue to be a reliable supplier of high-quality rolling stock while providing flexible repair services and will continue the rich tradition of Czech manufacturing of diesel and electric locomotives. In addition to cooperating with domestic buyers, CZ LOKO increasingly manufactures products for export to Italy, Finland, Turkey, Hungary, Poland, the Baltic states, Russia, the Balkans and many other countries.

## Important business partners of CZ LOKO, a.s.

- A** Achenseebahn
- ALB** A.B.C.D. Tirana | HSH Albanian Railways
- BIH** BES Company | JP Elektroprivreda Sarajevo | Termoelektrana TUZLA | RMU Breza | RMU Kakanj | Sisecam Soda Lukavac
- BLG** SIMEX | TEC - Bobov Dol EAD
- BYS** Beloruskaja Železnaja Doroga | ASB Leasing
- CZ** Advanced World Transport, a.s. | ArcelorMittal Ostrava, a.s. | AŽD Praha s.r.o. | BF Logistics, s.r.o. | Coal Services, a.s. | ČD Cargo, a.s. | České dráhy, a.s. | Dopravní podnik hl. m. Prahy - METRO | Elektrizace železnic Praha a.s. | INEKON GROUP, a.s. | RM LINES, a.s. | SD - Kolejová doprava, a.s. | Sokolovská uhelná, a.s. | Správa železniční dopravní cesty, s.o. | STRABAG Rail a.s. | ŠKODA AUTO, a.s. | TRINECKÉ ŽELEZÁRNY, a.s. | UNIPETROL DOPRAVA, s.r.o. | VÍTKOVICE Doprava, a.s. | IDS CARGO, a.s. | RAIL CARGO CARRIER s.r.o. | KDS | JUNIOR MARKET s.r.o. | KOTOUČ ŠTRAMBERK s.r.o. | SŽDS a.s.
- D** ArcelorMittal Eisenhüttenstadt, GmbH | Brunnhuber Eisenhüttenstadt | Railsystems RP
- EST** Port of Sillamäe – SILPORT | EVR Cargo
- FIN** Fennia Rail Oy
- H** Budapesti Közlekedési Zrt. | GanzPlan Hungaria | MÁV Debrecen | MOVILL | Swietelsky Budapest | CER Hungary
- ITL** Adriatico Sangritana S.p.A. | Dinazzano PO S.p.A. | Del Fungo Giera Ferrovia | Ferrovie Sud Est | Serfer Servizi Ferroviari S.r.l. | Terminali Italia S.r.l. | Francesco Ventura Costruzioni Ferroviarie S.r.l.
- LT** Lietuvos Geležinkeliai | Transmasholding Baltija | VLRD Vilnius
- LV** Latvijas dzelzceļš | LDZ RSS
- NL** ACTS Netherland | Short lines
- PL** Ciech CARGO Sp. z o.o. | DB Schenker Rail Tabor S.A. | EURONAF T S.A. | KWB „Adamow“, S.A. | Industrial Division Sp. z o.o. | Lubelski Węgiel „BOGDANKA“ S.A. | METRO Warszawskie Sp. z o.o. | OLPP, S.A. | ORGANIKA Nowa Sarzyna, S.A. | ORLEN Kol Trans, Sp. z o.o. | Pojazdy Szynowe PESA Bydgoszcz S.A. | POL-MIEDZ Trans, Sp. z o.o. | PUK Kolprem Sp. z o.o. | STK S.A. | TRANSCHEM, Sp. z o.o.
- RUS** ZAO Transmasholding
- SK** BJS Slovakia | Slovnaft Bratislava | U.S. Steel Košice, s.r.o. | Železnica spol. Cargo Slovakia | Železnica spoločnosť Slovensko | CER Slovakia a.s. | PSŽ a.s. | RTI a.s.
- SRB** AD „Železnice Srbije“ | JP EPS Beograd | KlimaShop Begec | Kombinovani prevoz | NIS / GAZPROM NEFT (Rafinerija Pancevo) | MarexTrade Beograd | PD Rudarski basen „Kolubara“ d.o.o. | TENT Obrenovac
- TR** TCDD | ERDEMIR
- UA** OAO „Teplovozoremontnyj zavod“ Poltava
- ITL** Ferrovie Nord Cargo S.r.l. | Rail Traction Company | Railconsult Mantova | Schenker Italiana S.p.A. | Servizi Ferroviari Integrati S.r.l. | Sistemi Territoriali S.p.A. | TIBER.CO / Linea Ferroviaria | TRENORD S.r.l.

**CZ LOKO**

*Locomotion Excellence<sup>®</sup>*

---

# PRODUCTION OF NEW AND MODERNISED LOCOMOTIVES AND SPECIAL VEHICLES



**TOTAL**  
**1004**  
units

# DEVELOPMENT OF THE COMPANY



1966

REPAIRS OF DIESEL-ELECTRIC LOCOMOTIVES

**CZ LOKO**  
POLSKA

2001

CZ LOKO POLSKA INCORPORATION

2004

STRATEGIC PARTNERSHIP WITH ZEPPELIN CZ S.R.O. COMPANY (CATERPILLAR)



2012

THE FIRST FOUR-AXLE LOCOMOTIVE MADE WITH ASYNCHRONOUS POWER TRANSFER



2017

FIRST COMPLETE MODERNISATION OF THE ELECTRIC LOCOMOTIVE EFFILINER 3000



1849

START-UP OF LOCOMOTIVE AND RAILWAY CAR REPAIRS



1988

REPAIRS OF ELECTRIC LOCOMOTIVES



2003

THE FIRST OWN DESIGNED DIESEL-ELECTRIC ENGINE



2008

THE FIRST LOCOMOTIVE MADE WITH ASYNCHRONOUS POWER TRANSFER



2016

THE FIRST LOCOMOTIVE MADE ACCORDING TO THE TSI STANDARDS  
CZ LOKO ITALIA ESTABLISHED

**CZ LOKO**  
ITALIA

**CZ LOKO**  
*Locomotion Excellence®*

# CZ LOKO SITES

ČESKÁ  
TŘEBOVÁ



JIHLAVA



PŘEROV



---









# CZ LOKO LOCOMOTIVES

**CZ LOKO, a.s** is a leading European manufacturer of diesel-electric and electric locomotives in the Czech Republic with a unique offer of solutions for the development of locomotive fleets. The product portfolio includes the production of new locomotives, complex modernisation, all levels of repairs, maintenance and renting of rail vehicles. The modular concept and overall unification ensure a high level of reliability while maintaining low operating and maintenance costs. CZ LOKO locomotives meet the strictest safety and environmental standards. Their standard equipment includes a digital control system, cruise control or automatic speed control, multi-control operation, remote GPS/GSM monitoring, on-board diagnostics, engine preheating, wheel slip protection, wheel flange lubrication and more.

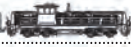
Modern CZ LOKO locomotives are thus not only environmentally friendly, but also significantly reduce operating and maintenance costs. This greatly contributes to the overall operation economy. For this reason, CZ LOKO products are popular with customers from all over the world.



**CZ LOKO**  
*Locomotion Excellence®*

CAT C13, 328 kW 1 250 t/8,9 km/h		<b>EffiShunter 300</b> page 3 - 6
CAT C18, 563 kW 2 450 t/9 km/h		<b>EffiShunter 600</b> page 7 - 8
CAT C32, 895 kW 2 650 t/14,5 km/h		<b>EffiShunter 1 000</b> page 9 - 12
CAT C3508B, 970 kW 2 700 t/16 km/h		<b>EffiShunter 1 000</b> page 9 - 12
CAT 3512C HD, 1 550 kW 4 000 t/16,2km/h		<b>EffiShunter 1600</b> page 13 - 16
CAT 3508B, 970 kW 4 000 t/9,3 km/h		<b>EffiShunter 1600</b> page 13 - 16
CAT 3512C, 1550 kW 4 000 t/15,9km/h		<b>C30-M</b> page 17 - 18
CAT 3512C HD, 1 550 kW 2 050 t/30 km/h		<b>EffiLiner 1600</b> page 19 - 20
3 kV DC / 25 kV 50 Hz AC, 2 910 kW 2 000 t/67,5 km/h		<b>EffiLiner 3000</b> page 21 - 22
2x MTU 16V 4000 R43, 2x 2 200 kW 8 000t / 22,6 km/h		<b>2M62UM</b> page 23 - 24

### SPECIAL VEHICLES

CZ LOKO has developed and produced numerous new and modernised special vehicles for construction, renewal and maintenance of lines, including diagnostics. Due to the transfer of traction forces by modern systems, unification of parts and numerous optional technologies and working superstructures, the vehicle enables operators to significantly increase work team productivity while maintaining the safety of people and equipment.

### PARAMETERS / OPTIONAL ACCESSORIES

### VEHICLE



**MUV 75**  
page 25- 26



The EffiShunter 300 diesel locomotive is primarily designed for shunting service. The locomotive is equipped with alternating/direct current power transfer (AC/DC) from the diesel engine to two powered wheelsets. Parameters of the vehicle are optimized for shunting in depots and stations, and for operation on industrial sidings and special lines (e.g. the underground).

## BENEFIT AND ADVANTAGES

- High reliability
- Low operating and maintenance costs
- Ecological operation
- Modern concept and design
- Use of unified solutions
- High comfort and operator safety
- Excellent field of view
- Spacious and safe platforms for shunters
- Service interval: 5 000 km / 2 months



The two-axle vehicle undercarriage consists of individually powered wheelsets with suspension and shock-absorption. The traction motors are fitted to the axles using sliding axle-mounted bearings. The drive unit is located in the front hood of the locomotive and comprises a Caterpillar diesel engine and a Siemens traction alternator. The front hood space includes most of the auxiliary drives, engine cooling block and a pneumatic unit. Electrical switchgear is installed in the rear hood. The power regulation and control of the entire locomotive is provided by a MSV elektronika control system with cruise control function and remote diagnostics by means of GSM and GPS technologies. The locomotive is equipped with a DAKO parking (stored-energy) brake and air brake.

## PARAMETERS EffiShunter 300

Track gauge	1 435 mm	1 520 mm
Meets the standards	TSI	GOST
Number of powered axles	2	
Wheelset arrangement	Bo	
Maximum operating speed	60 km/h	
Minimum curve radius	60 m	
Line category	A	
Lateral compatibility	2	
Power transmission	electric AC/DC	
Diesel engine	CAT C13	
EU Stage	IIIB	IIIA
Engine output	328 kW	
Maximum towing capacity	97 kN	
Nominal weight	36 t	
Axle load	18 t	
Compressor output	108 m <sup>3</sup> /h	
Fuel tank volume	700 l	
Climate class	-40 to +40 °C	

## EQUIPMENT

- Digital control system
- Cruise control
- Remote monitoring via GSM and GPS technologies
- Multiple control
- Knorr oil-free compressor
- Air drier
- Stored-energy, spring-actuated parking brake
- Wheel slip protection (at traction)

## OPTIONAL EQUIPMENT

- Anti-skid device (during braking)
- Remote radio control
- Automatic shunting coupler
- Camera system

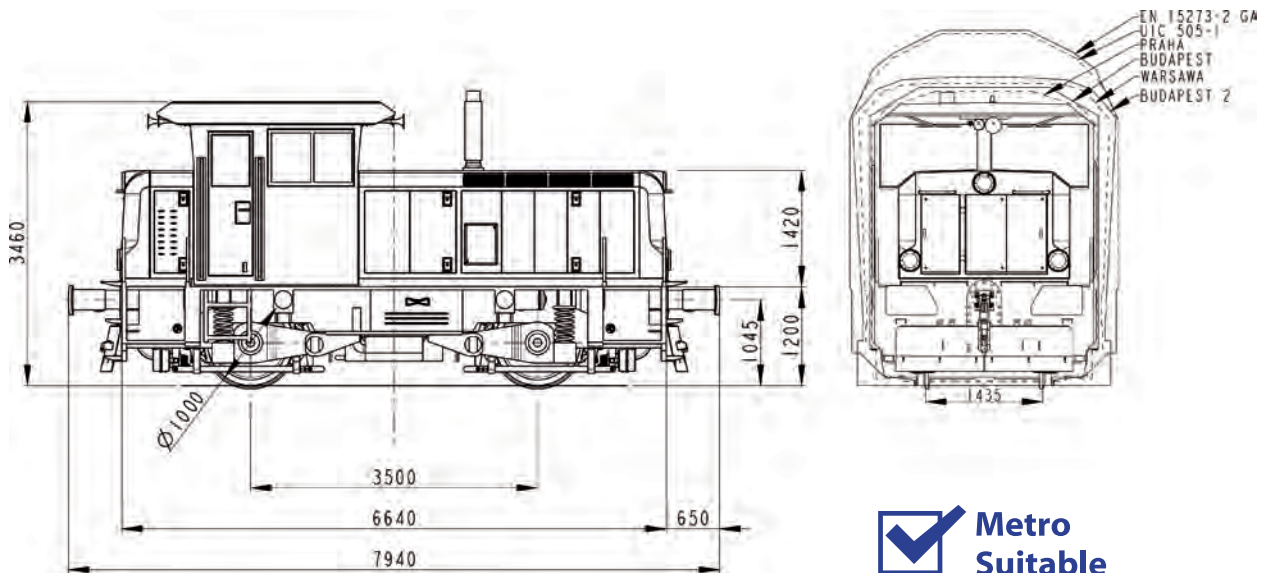

## LOCOMOTIVE MODEL DRAWING 1435

## LOAD DIAGRAM 1435

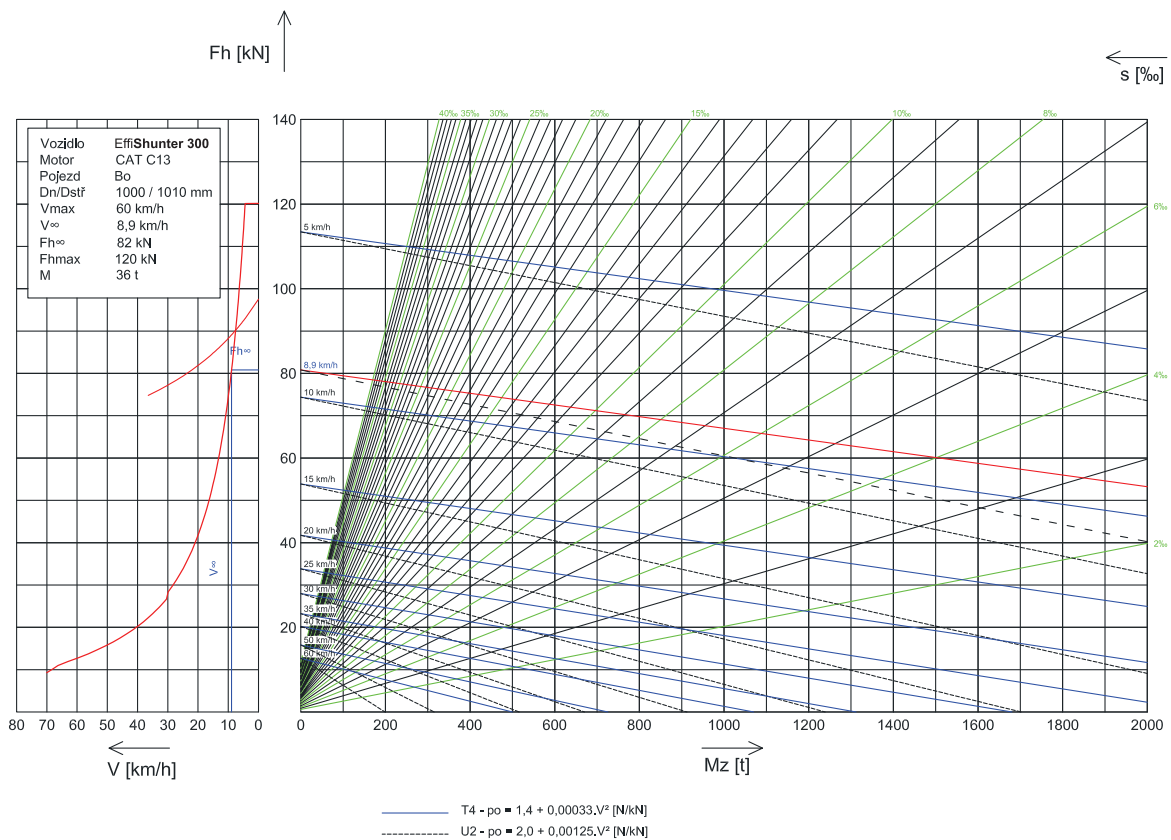

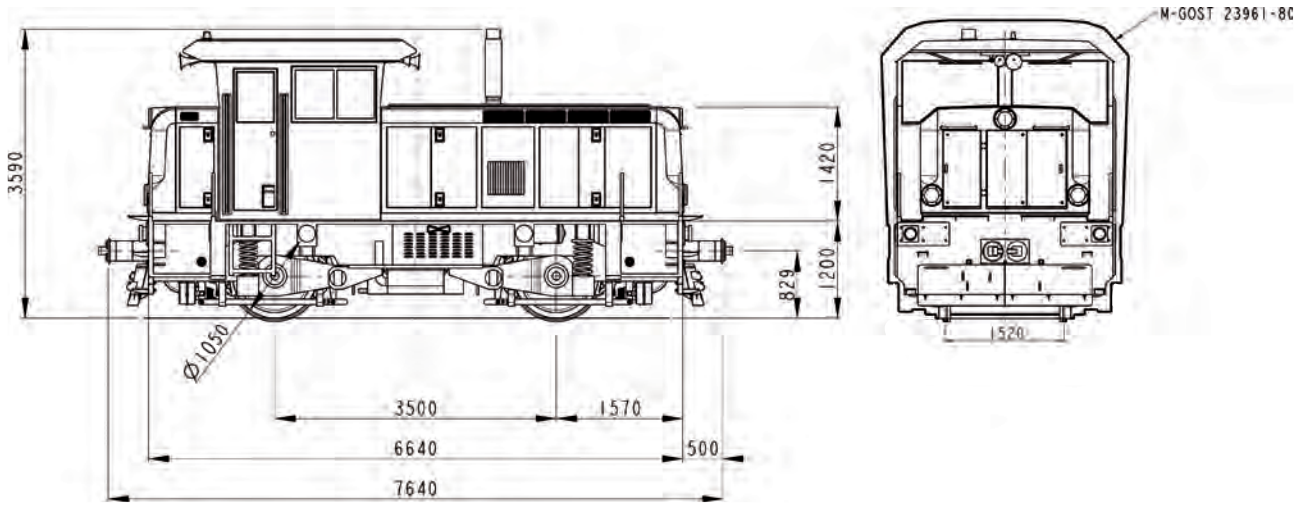

## LOCOMOTIVE MODEL DRAWING 1520

## LOAD DIAGRAM 1520

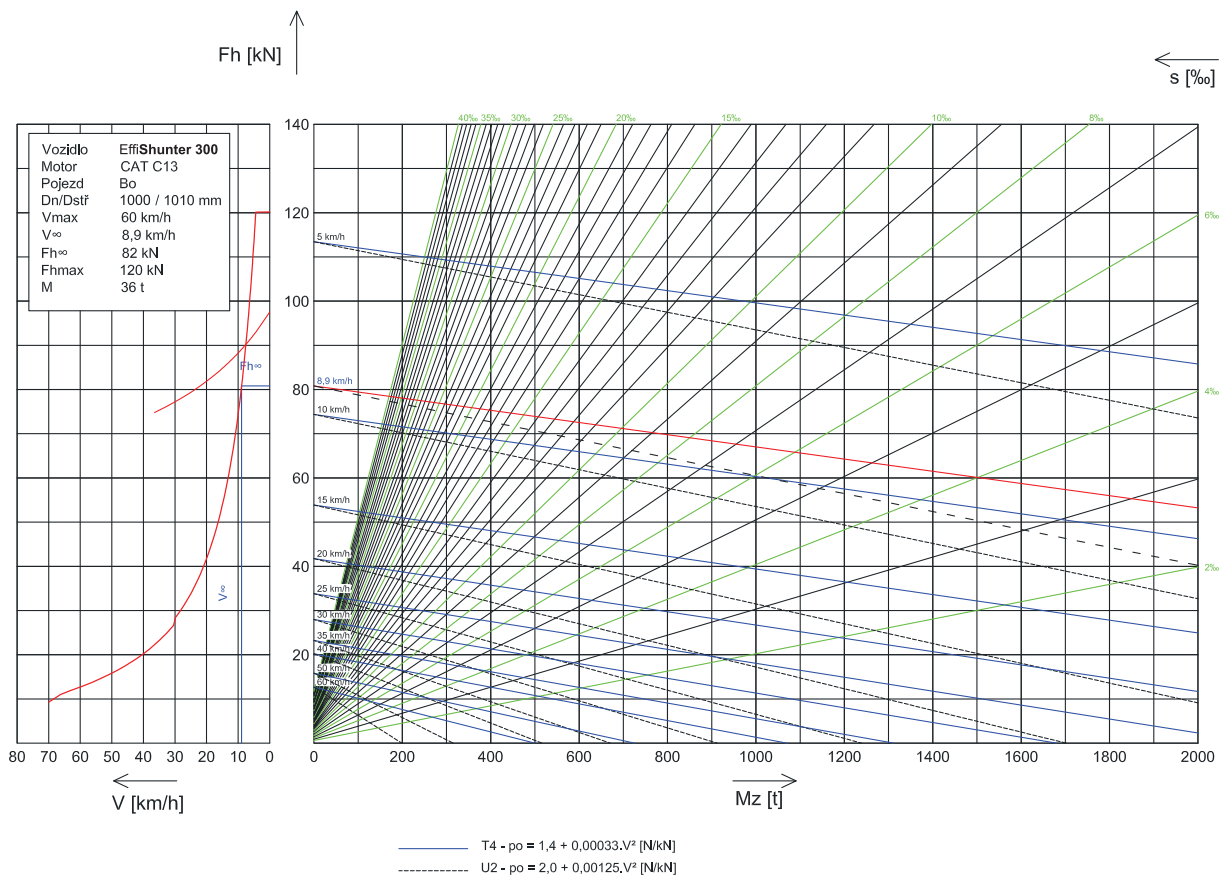



# EFFISHUNTER<sup>®</sup>

## 600

The EffiShunter 600 diesel locomotive is primarily intended for shunting service. The locomotive is equipped with alternating/direct current power transfer (AC/DC) from the diesel engine to four powered wheelsets. Parameters of the vehicle are optimized for station shunting and for operation on industrial sidings, e.g. in metallurgical, mining and petrochemical sectors.

## BENEFIT AND ADVANTAGES

- High reliability
- Low operating and maintenance costs
- Ecological operation
- Modern concept and design
- Use of unified solutions
- High comfort and operator safety
- Excellent field of view
- Spacious and safe platforms for shunters
- Service interval: 10 000 km / 2 months



The undercarriage of the locomotive comprises two double-axle bogies with individual drive of all wheelsets. The traction motors are nose-suspended on the axles using sliding or roller bearings. The drive unit is located in the front hood of the locomotive and comprises a Caterpillar diesel engine and a Siemens traction alternator. The front hood space includes most of the auxiliary drives, engine cooling block and a pneumatic unit. The rear hood contains an electric switchboard and the electro-dynamic brake block if opted. The power regulation and control of the entire locomotive is provided by a MSV elektronika control system with cruise control function and remote diagnostics by means of GSM and GPS technologies. The locomotive is equipped with a DAKO air brake and a parking (hand) brake. The locomotive can also be equipped with an electro-dynamic brake (EDB).

## PARAMETERS EffiShunter 600

Track gauge	1 435 mm
Meets the standards	EN
Number of powered axles	4
Wheelset arrangement	B'o B'o
Maximum operating speed	80 km/h
Minimum curve radius	80 (60) m
Line category	B1
Lateral compatibility	1
Power transmission	electric AC/DC
Diesel engine	CAT C18
EU Stage	IIIB
Engine output	563 kW
Maximum towing capacity	222 kN
Nominal weight	72 t
Axle load	18 t
Compressor output	140 – 175 m <sup>3</sup> /h
Fuel tank volume	4 000 l
Climate class	-25 to +40 °C

## EQUIPMENT

- Digital control system
- Cruise control
- Remote monitoring via GSM and GPS technologies
- Multiple control
- Air drier
- Wheel slip protection (at traction)

## OPTIONAL EQUIPMENT

- Electro-dynamic brake (EDB)
- Anti-skid device (during braking)
- Deformation elements
- Roller bearings on traction motors
- Remote radio control
- Automatic shunting coupler
- Camera system

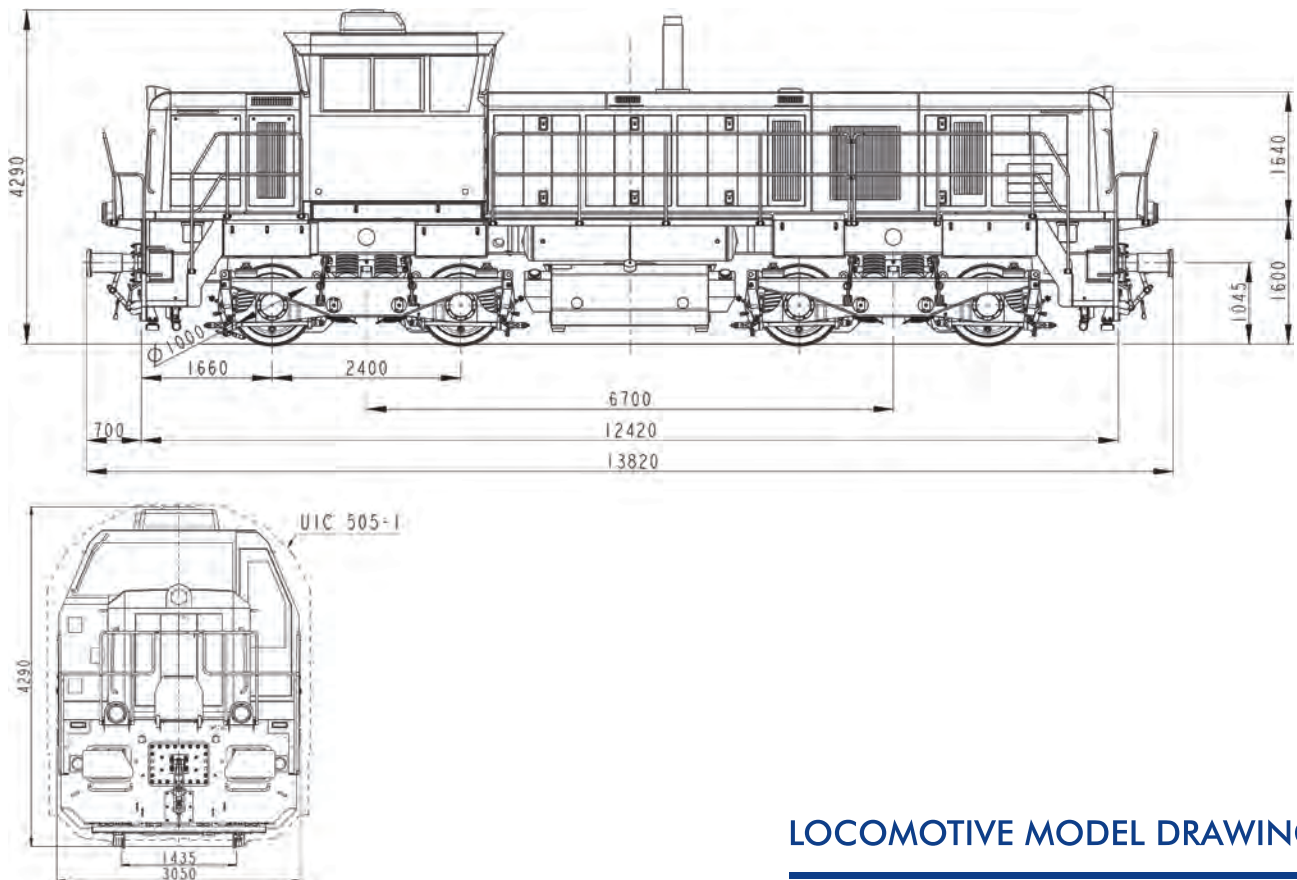

## LOCOMOTIVE MODEL DRAWING

## LOAD DIAGRAM

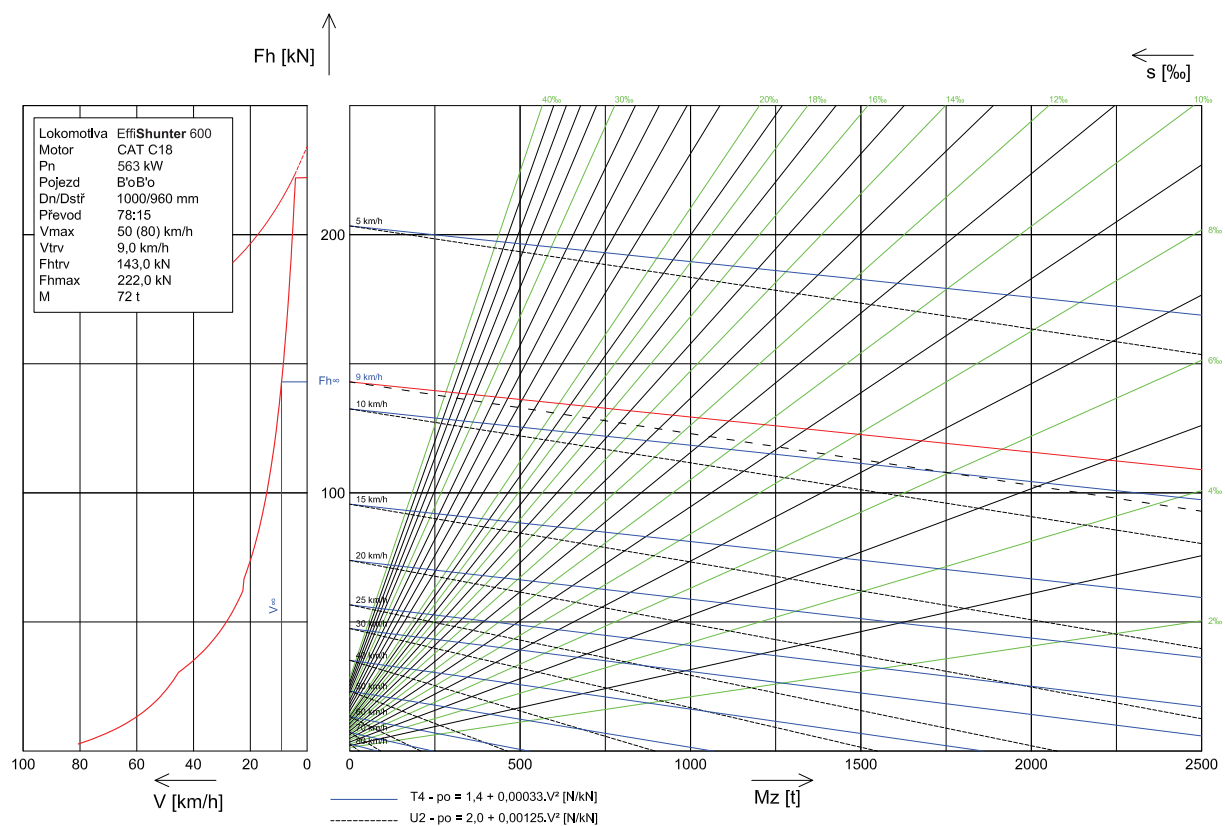

# EFFISHUNTER® 1000

The EffiShunter 1000 diesel locomotive is intended for shunting and line service. The locomotive is equipped with alternating power transfer (AC/AC) from the diesel engine to four powered wheelsets. For optimum use of the locomotive's power, the asynchronous traction motors are individually powered and controlled. Parameters of the vehicle are optimized for station shunting and for heavy operation on industrial sidings, e.g. in metallurgical, mining and petrochemical sectors with the possibility to perform line service.

## BENEFIT AND ADVANTAGES

- High reliability
- Low operating and maintenance costs
- Ecological operation
- Modern concept and design
- Use of unified solutions
- High comfort and operator safety
- Excellent field of view
- Spacious and safe platforms for shunters
- Service interval: 30 000 km / 2 months



The undercarriage of the locomotive comprises two double-axle bogies with individual drive of all wheelsets. The traction motors are nose-suspended on the axles using rolling bearings. The drive unit is located in the front hood of the locomotive and comprises a Caterpillar diesel engine and a Siemens traction alternator. The front hood space includes most of the auxiliary drives, engine cooling block and a pneumatic unit. The rear hood contains electric switchboards and an electro-dynamic brake block. The power regulation and control of the entire locomotive is provided by a MSV elektronika control system with cruise control function and remote diagnostics by means of GSM and GPS technologies. The locomotive is equipped with a DAKO parking (stored-energy) brake and air brake.

## PARAMETERS EffiShunter 1000

Track gauge	1 435 mm	1 520 mm
Meets the standards	TSI	GOST
Number of powered axles	4	
Wheelset arrangement	B'o B'o	
Maximum operating speed	100 km/h	
Minimum curve radius	80 m (65 m)	
Line category	B1	-
Lateral compatibility	1	-
Power transmission	electric AC/AC	
Diesel engine	CAT C32	CAT 3508 B
EU Stage	IIIB	II
Engine output	895 kW	970 kW
Maximum towing capacity	267 kN	
Nominal weight	80 t	92 t
Axle load	20 t	23 t
Compressor output	140 - 252 m <sup>3</sup> /h	210 m <sup>3</sup> /h
Fuel tank volume	4 200 l	
Climate class	-40 to +40 °C	-50 to +40 °C

## EQUIPMENT

- Digital control system
- Cruise control
- Remote monitoring via GSM and GPS technologies
- Multiple control
- Roller bearings on traction motors
- Air drier
- Disc brake
- Electro-dynamic brake (EDB)
- Stored-energy, spring-actuated parking brake
- Anti-skid equipment and wheel slip protection
- Deformation elements

## OPTIONAL EQUIPMENT

- Remote radio control
- Automatic shunting coupler
- Camera system

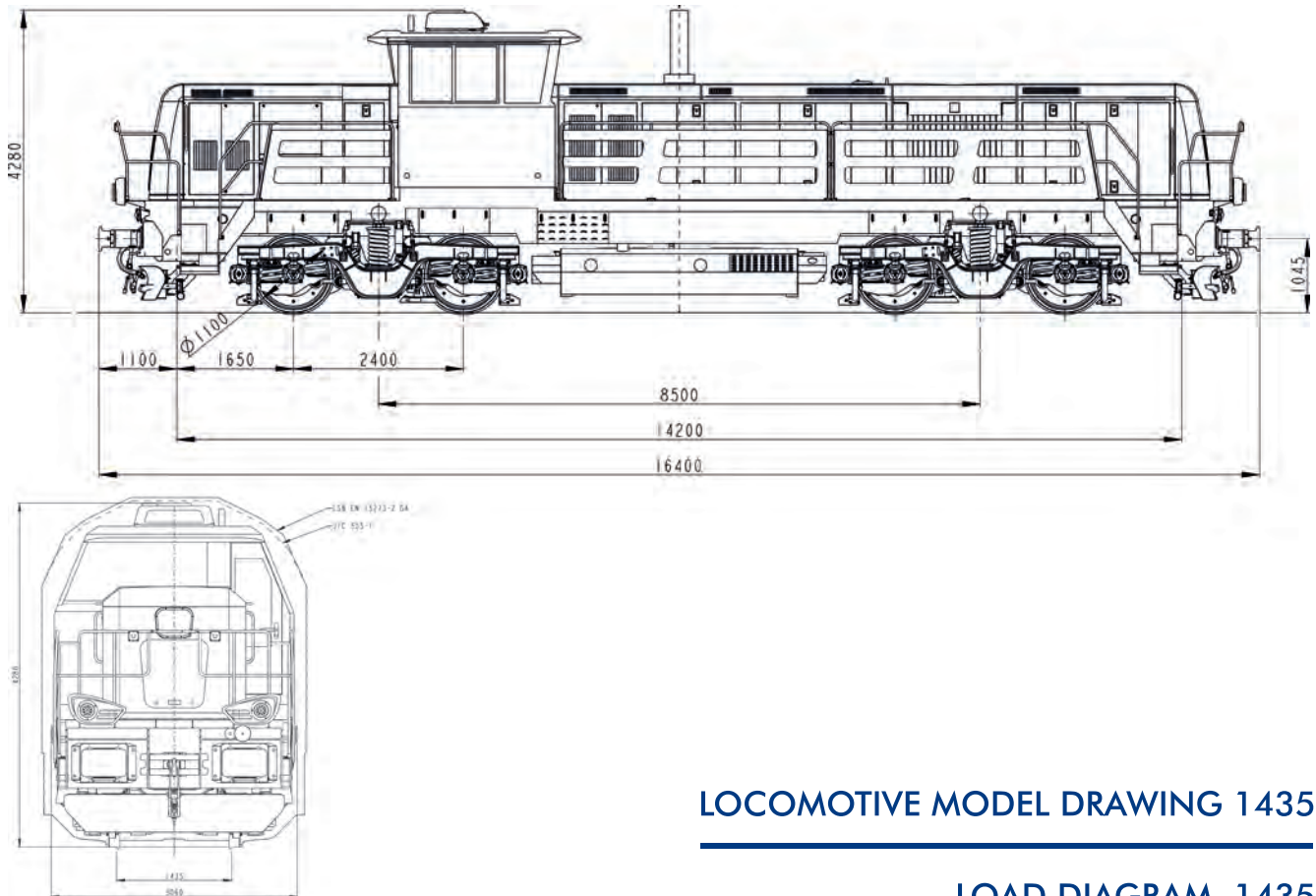

**LOCOMOTIVE MODEL DRAWING 1435**

**LOAD DIAGRAM 1435**

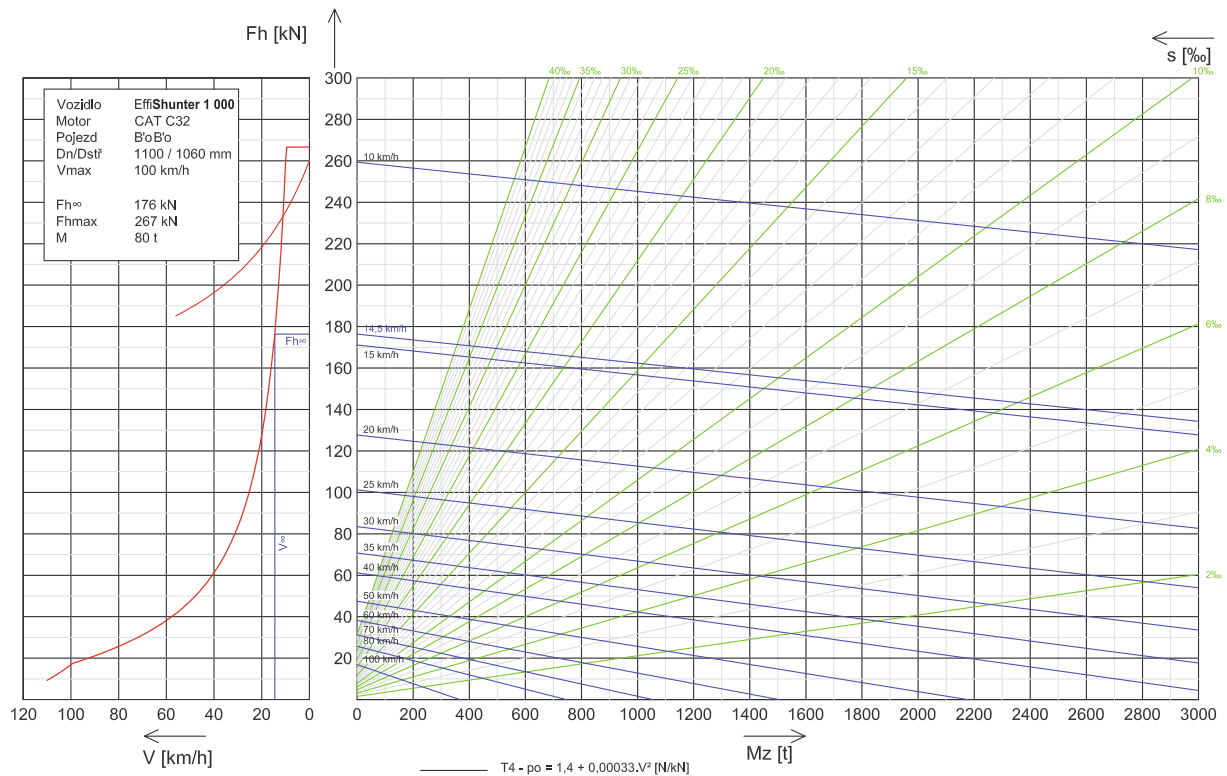

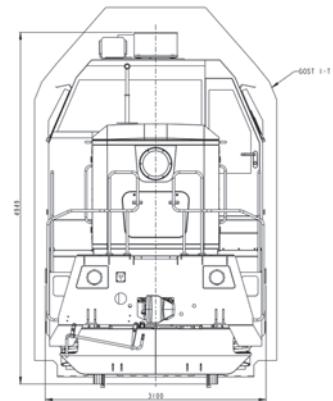
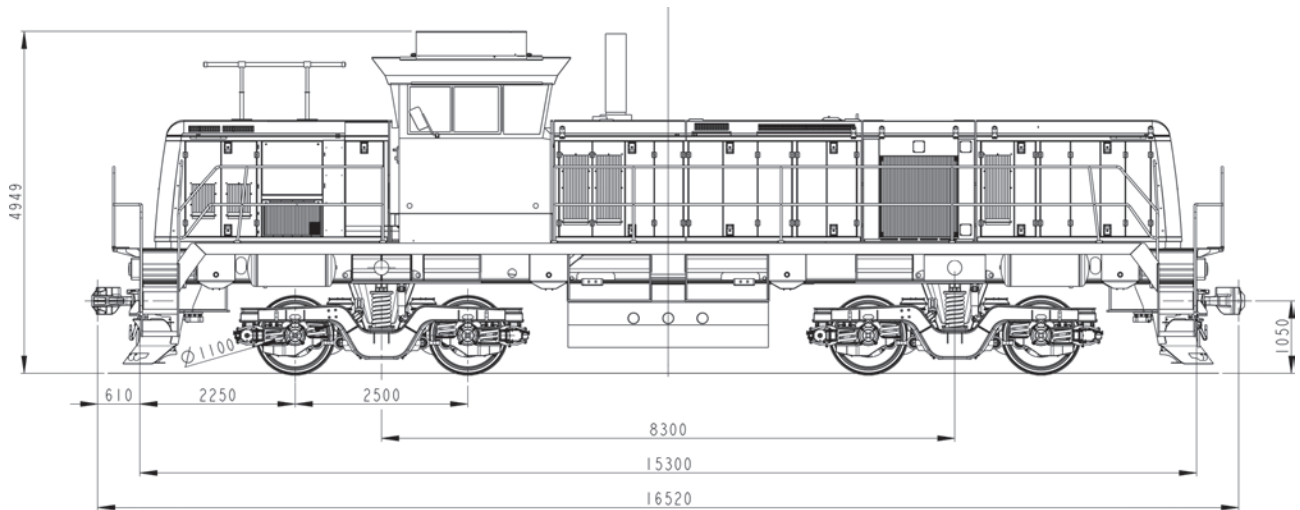

## LOCOMOTIVE MODEL DRAWING 1520

## LOAD DIAGRAM 1520

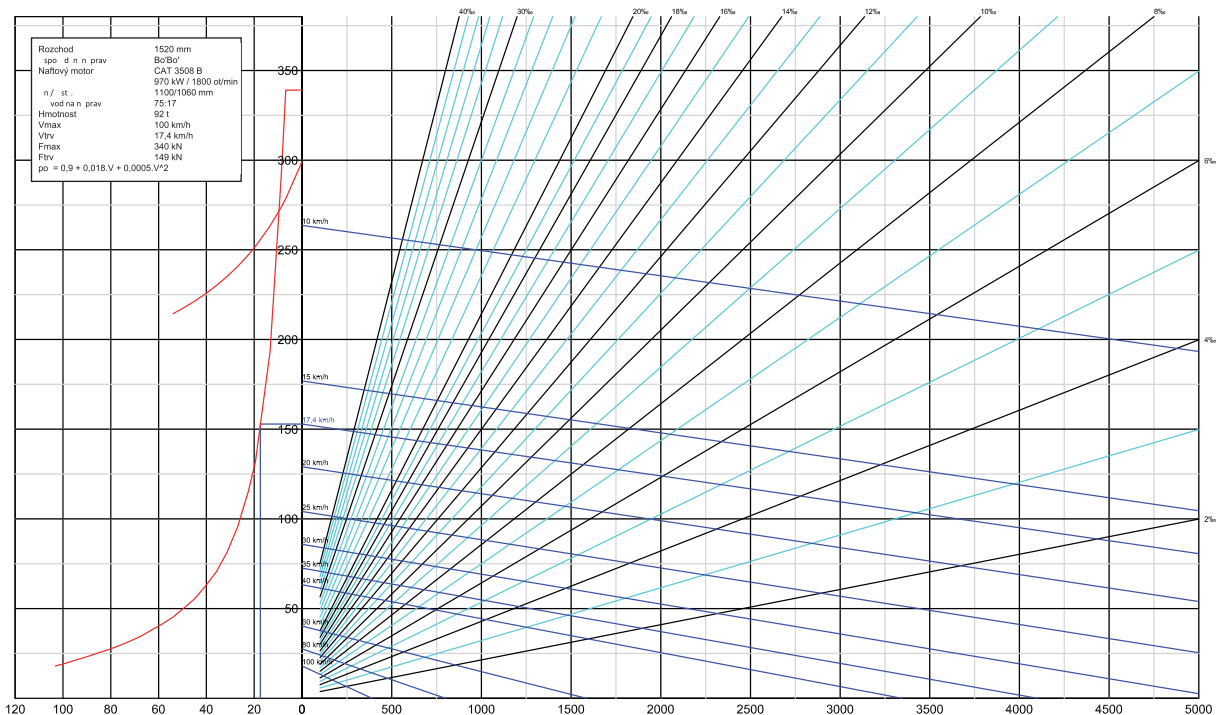

## MODERN CONCEPT

The new concepts for hoods, ventilation grilles and filters ensure maximum noise reduction. The new design of the frame enables recessing of the diesel engine. Along with low hoods, this solution enables a perfect field of view from the cab. This incredibly increased the operator's comfort and overview of the operating situation. CAT diesel engines provide highly economical operation with minimum idle consumption. Design solutions excel especially in low maintenance and operating costs.

## BOGIE

Guiding of wheelsets and transmission of towing and braking forces between the bogie frame and wheelset is provided by con rods. Suspension in both the primary and secondary stage is performed by FLEXI-COIL springs. The location of springs in the secondary stage is selected with respect to the reduction of torque against bogie rotation while maintaining drive stability on a straight track. Shock-absorption of both stages of suspension is ensured by hydraulic dampers. The used axle bearings are maintenance-free taper units with high durability. The axle-mounted traction motor is installed on the axle by means of roller bearings. The mechanical disc brake utilizes brake discs attached to the wheel plate and a brake unit is installed with a cleaning block ensuring good adhesion conditions.

## LOW OPERATING COSTS

The structure and design of the EffiShunter 1000 locomotive was conceived from the beginning as a set of operation-proven units showing high long-term reliability with a cost-efficient maintenance regime. Thanks to long-term monitoring and evaluation of behaviour of individual inter-changeable units, the EffiShunter 1000 locomotive can guarantee high reliability. The bogie design, output and design of the drive units, the hood shape and materials, as well as the new locomotive cab, were designed with regard to cost-efficient operation. Roller bearings on traction motors, the use of power-efficient electro-dynamic brakes (EDB) and disc brakes contributed to the extension of the scheduled maintenance interval up to 30,000 km. Electric auxiliary drives can operate without a system of V-belts and optimize the necessary input power from the drive unit.

## NOISE REDUCTION

The locomotive was designed with the goal to minimise external and internal noise. This is supported by the design of filters in the hoods as well as their insulation. Noise transmitted to driver's cab has also been minimised. Noise was also reduced by the design of the undercarriage with a disc brake. Substantial noise reduction while turning curves and at track crossings was achieved by wheel flange lubrication with grease, which reduces mechanical wear of wheel flanges.

## DIGITAL CONTROL SYSTEM

A perfect overview of the entire vehicle's diagnostic operating values enables the control system of the locomotive to select a safe and cost-efficient mode of train drive. Values are also recorded for consequent operational evaluation and transmitted to a remote server via GSM technology. The control system therefore provides a complete picture of the operation of the vehicle to the operator as well as the service team.

## MODERN AND FUNCTIONAL DESIGN

The characteristic design of the locomotive is not only an aerodynamic shell for the protection of modern components. Hoods also have many functional elements. They ensure air supply for cooling the drive units, while minimizing the noise transmission to the surrounding areas, preventing the ingress of water and thermally insulate internal areas. At the same time they have to enable easy access for maintenance of the vehicle. A modern driver's cab meets strict ergonomic and health requirements. The quality of driver's cab increases safety of operation.



# EFFISHUNTER® 1600

The class EffiShunter 1600 diesel locomotive is intended for shunting and line service. The locomotive is equipped with alternating/direct current power transfer (AC/DC) from the diesel engine to six powered wheelsets. Parameters of the vehicle are optimized for station shunting and for heavy operation on industrial sidings, e.g. in metallurgical, mining and petrochemical sectors, and for the line service.

## BENEFIT AND ADVANTAGES

- High reliability
- Low operating and maintenance costs
- Ecological operation
- Modern concept and design
- Use of unified solutions
- High comfort and operator safety
- Excellent field of view
- Spacious and safe platforms for shunters
- Service interval: 10 000 km / 2 months



The undercarriage of the locomotive comprises two three-axle bogies with individual drive of all wheelsets. The traction motors are nose-suspended on the axles using sliding or roller bearings. The drive unit is located in the front hood of the locomotive and comprises a Caterpillar diesel engine and a Siemens traction alternator. The front hood space includes most of the auxiliary drives, engine cooling block and a pneumatic unit. The rear hood contains electric switchboards and an electro-dynamic brake block. The power regulation and control of the entire locomotive is ensured by a MSV elektronika control system with cruise control or automatic speed control (ARR) function and remote diagnostics by means of GSM and GPS technologies. The locomotive is equipped with a DAKO/MT3 Transmaš air brake, a parking (hand) brake and an electro-dynamic brake (EDB).

## PARAMETERS EffiShunter 1600

Track gauge	1 435 / 1 524 mm	1 520 mm
Meets the standards	TSI	GOST
Number of powered axles	6	
Wheelset arrangement	C'o C'o	
Maximum operating speed	90 km/h	
Minimum curve radius	120 m	
Line category	C2	-
Lateral compatibility	3	-
Power transmission	electric AC/DC	
Diesel engine	CAT 3512 C-HD	CAT 3508 B
EU Stage	IIIA	II
Engine output	1 550 kW	970 kW
Maximum towing capacity	383 kN	
Nominal weight	115,2t	126 t
Axle load	19,2t	21 t
Compressor output	252 m <sup>3</sup> /h	360 m <sup>3</sup> /h
Fuel tank volume	4 500 - 5 000 l	
Climate class	-40 to +40 °C	-50 to +40 °C

## EQUIPMENT

- Digital control system
- Cruise control or automatic speed control (ARR)
- Remote monitoring via GSM and GPS technologies
- Multiple control
- Roller bearings on traction motors
- Air drier
- Electro-dynamic brake (EDB)
- Wheel slip protection (at traction)
- Deformation elements

## OPTIONAL EQUIPMENT

- Roller bearings on traction motors
- Anti-skid device (during braking)
- Remote radio control
- Automatic shunting coupler
- Camera system

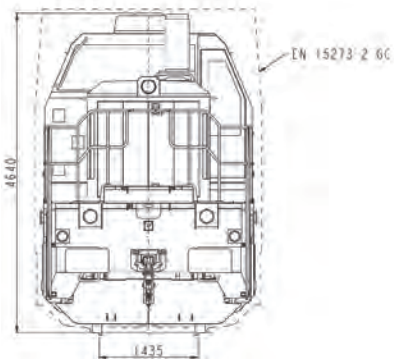
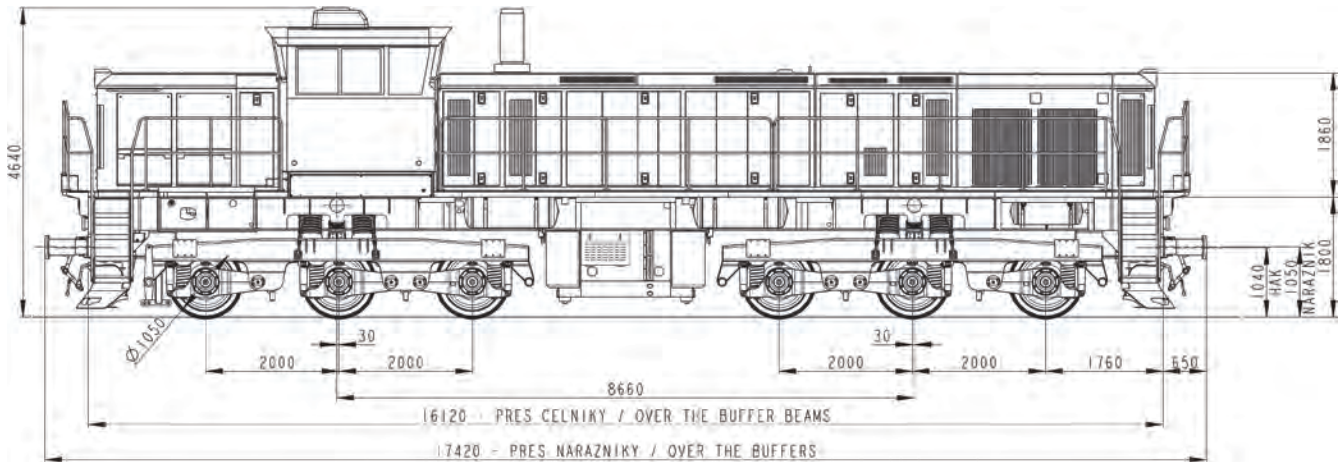

## LOCOMOTIVE MODEL DRAWING 1435

## LOAD DIAGRAM 1435

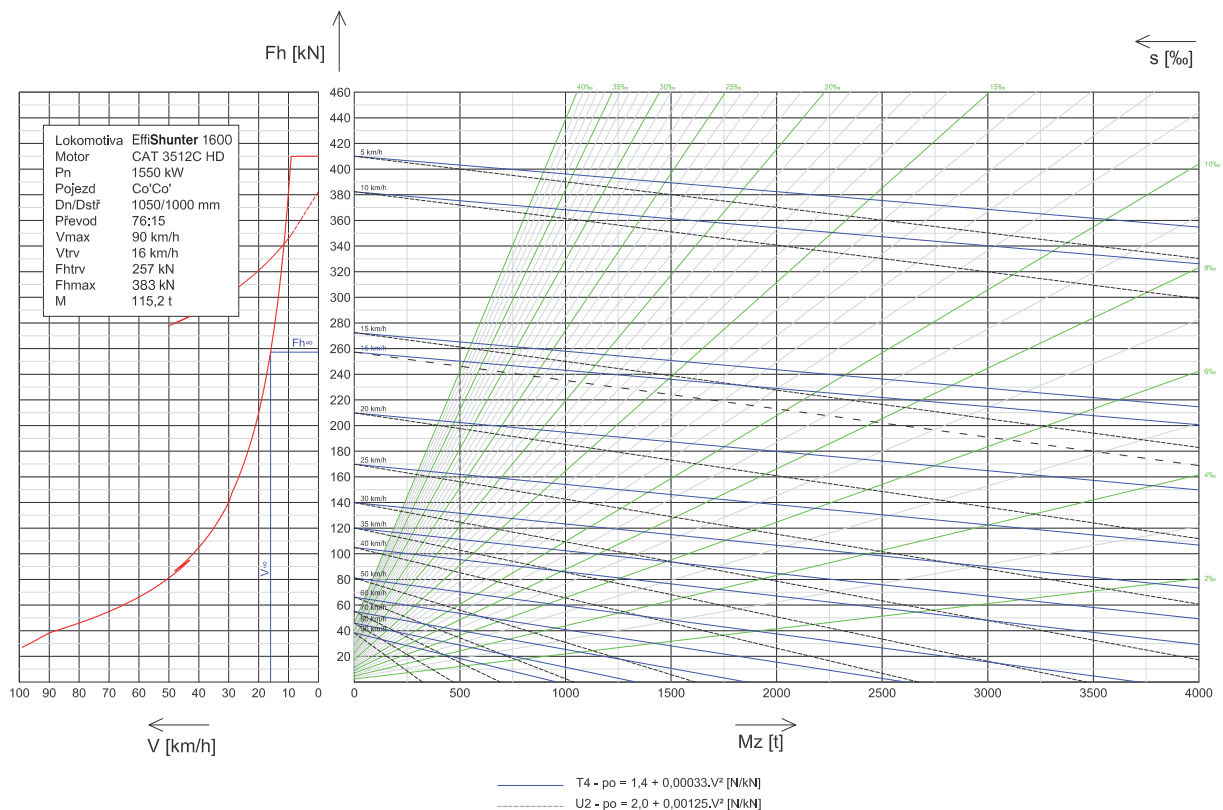

# EFFISHUNTER<sup>®</sup> 1600

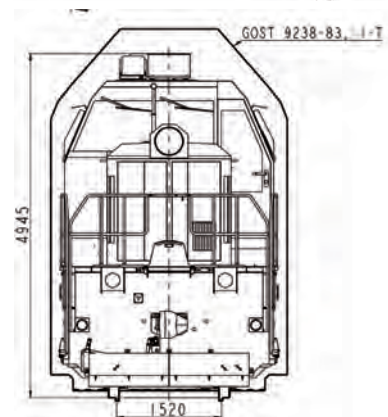
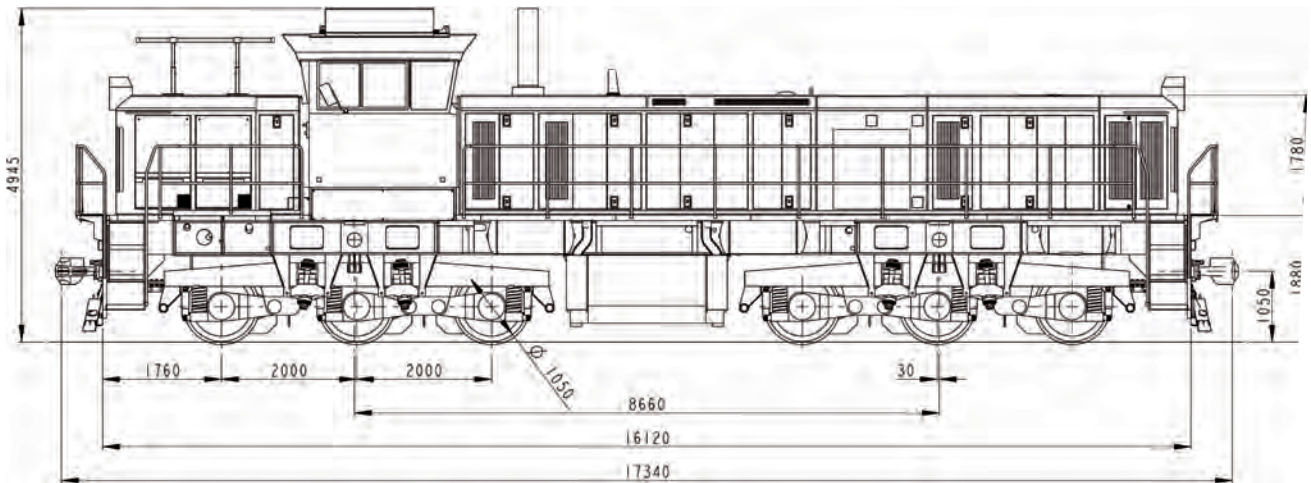

## LOCOMOTIVE MODEL DRAWING 1520

## LOAD DIAGRAM 1520

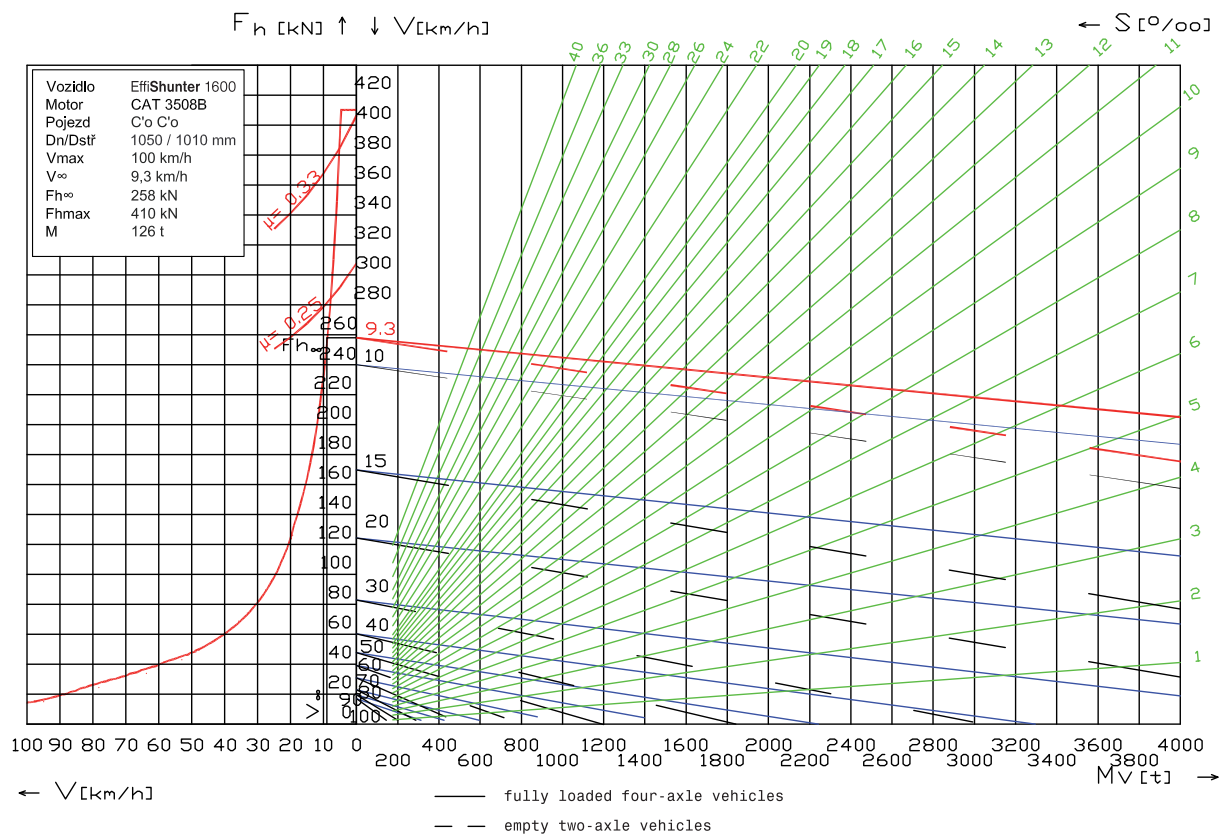



# C30-M

The class **C30-M** locomotive is designed for heavy shunting and line service on lines and sidings with a 1520mm gauge. The six-axle diesel locomotive with an axle load of 23 tons features electric AC/DC power transmission. The locomotive is designed as a hood unit type with a cab tower installed closer to the rear face of the main frame. Its wheelset arrangement is C'o C'o and the vehicle's maximum speed is 100 km/h. The locomotive was created by a complex modernization of the original class C30 locomotive (or derived types).

## BENEFIT AND ADVANTAGES

- Reliability
- Significant reduction of operation and maintenance costs
- Extended locomotive service life
- Ecological operation – emission limits EU Stage IIIA
- Modern concept
- Use of unified solutions
- High comfort and operator safety
- Excellent field of view



The main frame is mounted on two three-axle bogies, between which a fuel tank is located. The drive unit is mounted on the locomotive in the front hood. It consists of a Caterpillar 3512C diesel engine and a Siemens auxiliary traction alternator. The auxiliary alternator is powering electrically driven auxiliary drives (compressor with a cooler, traction motor cooling fans, etc.). Both of these machines are combined in one unit and through a common intermediate frame are mounted on the main frame of the locomotive. The power transmission from the engine to the powered wheelset is electrical, AC/DC and comprises a traction alternator, a rectifier and six original traction motors. The traction motor is individual for each wheelset, on which it is mounted using bearings. The front hood space includes most of the auxiliary drives, engine cooling block and a pneumatic unit. The rear hood space includes electric switchboards and two electro-dynamic brake (EDB) blocks. The power output control and the control of the entire locomotive is ensured by the electronic control system. The locomotive is fitted with three DAKO pneumatic brake systems, a mechanical hand brake (parking) and an electrodynamic brake.

## PARAMETERS C30-M

Track gauge	1520 mm
Meets the standards	EN
Number of powered axles	6
Wheelset arrangement	C'o C'o
Maximum operating speed	100 km/h
Minimum curve radius	80m
Line category	B1
Lateral compatibility	1
Power transmission	AC/DC
Diesel engine	CAT 3512C EU Stage IIIA
Engine output	1550 kW
Maximum towing capacity	436 kN
Nominal weight	138 t
Axle load	23 t
Compressor output	252 m <sup>3</sup> /h
Fuel tank volume	11 000 l
Climate class	-40 °C to +40 °C

## EQUIPMENT

- Multiple control
- Spacious and safe platforms for shunters
- Electro-dynamic brake (EDB)
- Air drier
- Wheel slip protection
- Option to fit a radio remote control
- Option to fit an anti-skid device

# C30-M

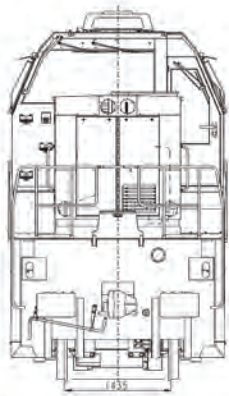
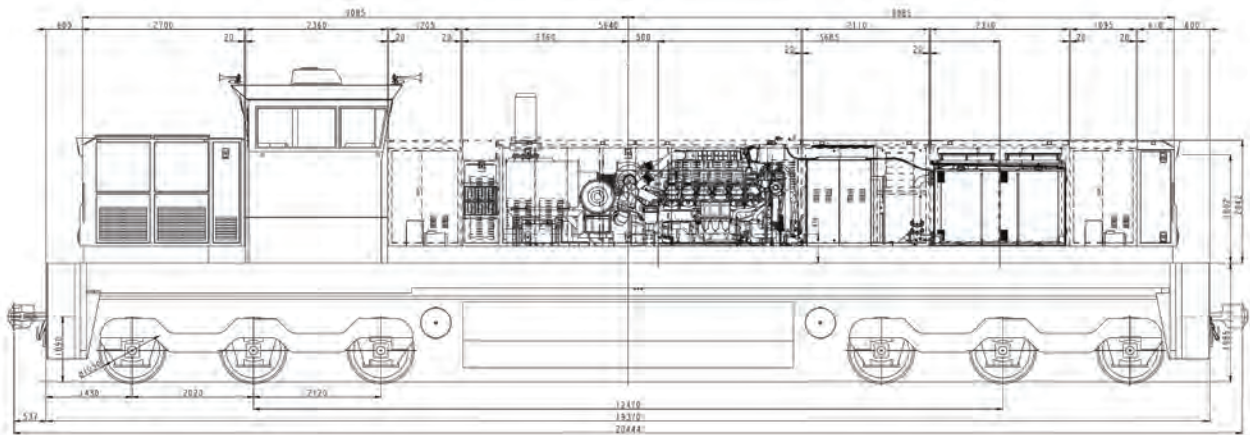

## LOCOMOTIVE MODEL DRAWING

## LOAD DIAGRAM

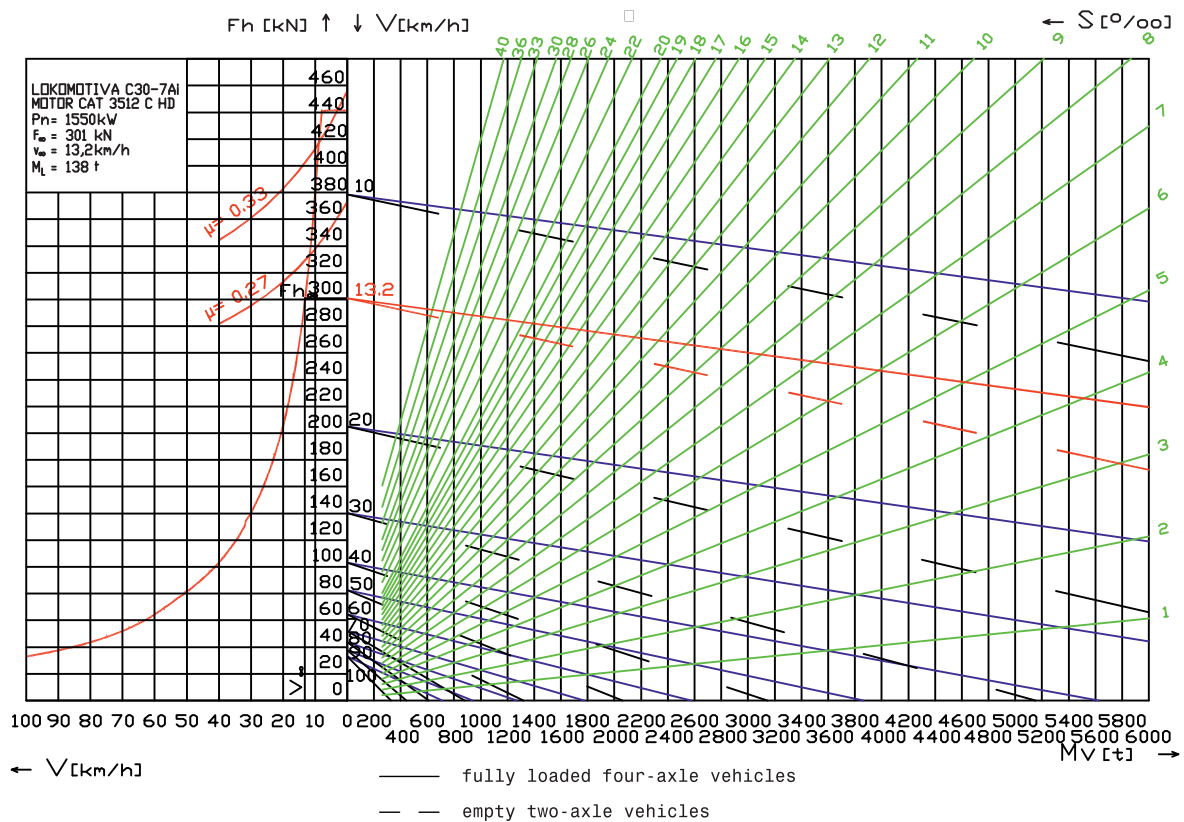

The class EffiLiner 1600 diesel locomotive is designed as a cab unit type with two driver's cabs. The locomotive is equipped with alternating/direct current power transfer (AC/DC) from the diesel engine to four powered wheelsets. Parameters of the vehicle are optimized for line service.

## BENEFIT AND ADVANTAGES

- High reliability
- Low operating and maintenance costs
- Ecological operation
- Modern concept and design
- Use of unified solutions
- High comfort and operator safety
- Excellent field of view
- Service interval: 10 000 km / 2 months



The undercarriage of the locomotive comprises two double-axle bogies with individual drive of all wheelsets. The traction motors are nose-suspended on the axles using rolling bearings. The drive unit is located in the engine room and comprises a Caterpillar diesel engine and a Siemens traction alternator. In the engine room there are also auxiliary drives, a diesel engine cooling block, a pneumatic block and a switchboard with an electrodynamic brake block. The power regulation and control of the whole locomotive is ensured by a MSV elektronika control system with automatic speed control (ARR) function and remote diagnostics by means of GSM and GPS technologies. The locomotive is equipped with a DAKO parking (stored-energy) brake and air brake.

## PARAMETERS EffiLiner 1600

Track gauge	1 435 mm
Meets the standards	EN
Number of powered axles	4
Wheelset arrangement	B'o B'o
Maximum operating speed	100 km/h
Minimum curve radius	100 m
Line category	B1
Lateral compatibility	1
Power transmission	electric AC/DC
Diesel engine	CAT 3512 C-HD
EU Stage	IIIA
Engine output	1 550 kW
Maximum towing capacity	206 kN
Nominal weight	76 t
Axle load	19,5 t
Compressor output	175 m <sup>3</sup> /h
Fuel tank volume	5 000 l
Climate class	-25 to +40 °C

## EQUIPMENT

- Digital control system
- Automatic speed control (ASC)
- Remote monitoring via GSM and GPS technologies
- Multiple control
- Roller bearings on traction motors
- Air drier
- Electro-dynamic brake (EDB)
- Stored-energy, spring-actuated parking brake
- Anti-skid equipment and wheel slip protection
- Deformation elements
- Camera system

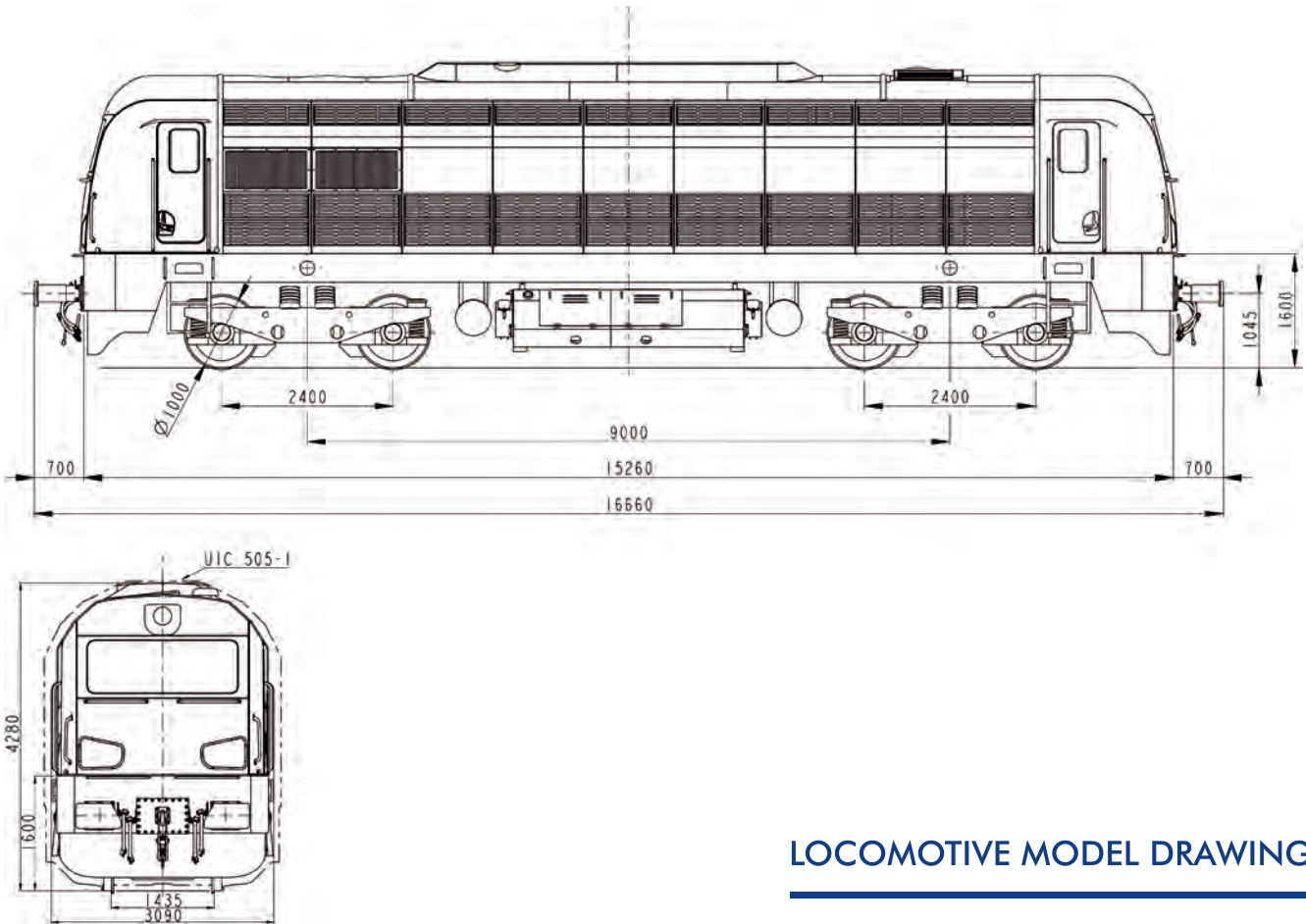

**LOCOMOTIVE MODEL DRAWING**

**LOAD DIAGRAM**

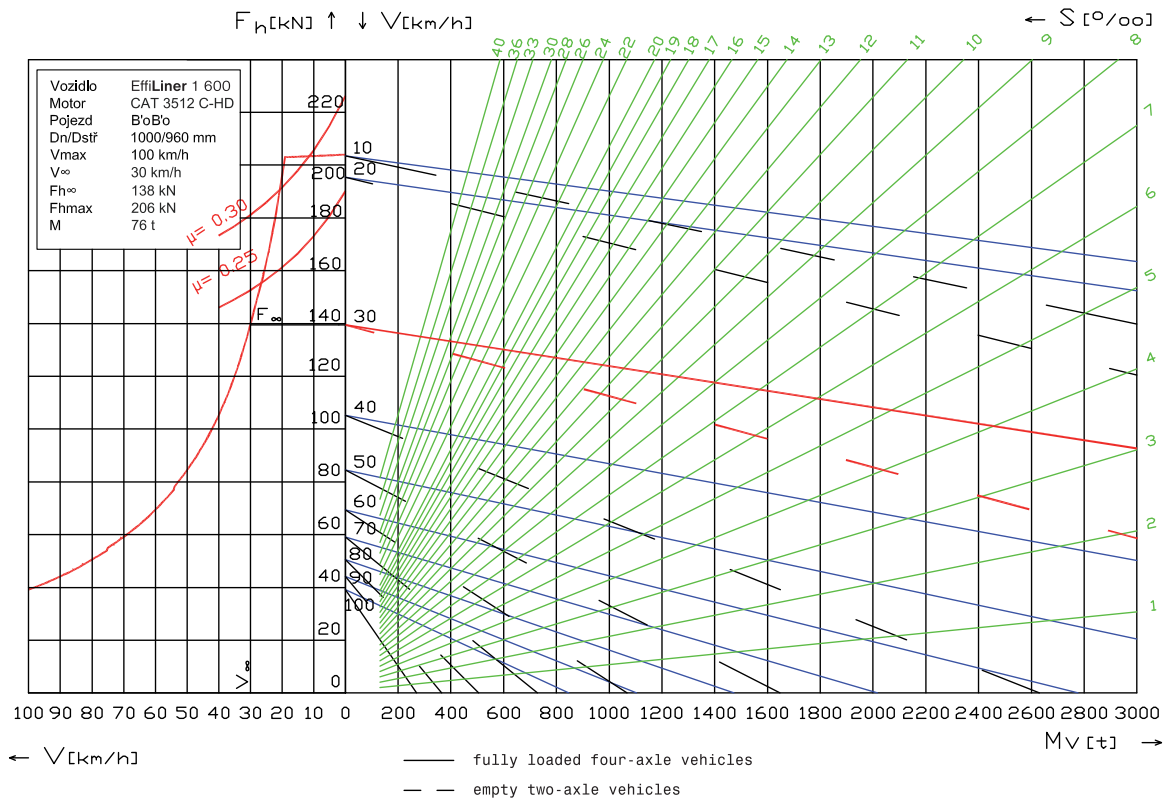

# EFFLINER<sup>®</sup> 3000

Electric locomotive EffiLiner 3000 is primarily intended for line service on national as well as regional lines. The parameters of the modernized dual-system locomotive originally designated Class 12 are optimized for mid-range performance.

## BENEFIT AND ADVANTAGES

- High reliability
- Low operating and maintenance costs
- Ecological operation
- Use of unified solutions
- High comfort and operator safety
- Excellent field of view
- Service interval: 15 000 km / 2 months



The undercarriage of the locomotive comprises two double-axle bogies with individual drive of all wheelsets. Traction motors are firmly attached to axles and torque is transmitted via a flexible coupling. The locomotive chassis is mounted by means of coil springs on two two-axle bogies. Transfer of longitudinal forces from the undercarriages to the body and vice versa is provided by a towing unit. A nearly symmetrically arranged engine room is located between both cabs, containing traction inverters, fan systems cooling the traction inverters and traction motors, braking resistors, a pneumatic block and a low-voltage switchboard. The current intake from the overhead line is provided by two collectors. On the 25 kV 50 Hz AC power supply system, current flows from the collector to the traction transformer, the power supply of traction inverters is performed by powering from a 3kV DC network directly. When powering from a 25kV 50Hz AC network, two traction inverters are powered from two secondary transporter windings, one for each bogie. Inverters are equipped with IGBT transistors, which allow smooth power regulation in both the driving and brake mode, including recovery. The locomotive is equipped with three systems of air brakes (self-acting, direct-acting, additional), mechanical (locking) hand brake and electro-dynamic brake (EDB). The automatic DAKO-GP brake system operates in both the freight and the passenger mode.

## PARAMETERS EffiLiner 3000

Track gauge	1 435 mm
Meets the standards	TSI
Number of powered axles	4
Wheelset arrangement	B'o B'o
Maximum operating speed	120 km/h
Minimum curve radius	100 m
Voltage system	3 kV DC / 25 kV 50 Hz AC
Engine output	2910 kW
Maximum towing capacity	225 kN
Nominal weight	85 t
Axle load	21,25 t
Compressor output	252 m <sup>3</sup> /h
Climate class	-25 to +40 °C

## EQUIPMENT

- Digital control system
- Automatic speed control
- Remote monitoring via GSM and GPS technologies
- Master-slave mode
- Mattei compressor
- Air drier
- Wheel slip protection (at traction)
- Anti-skid device (during braking)

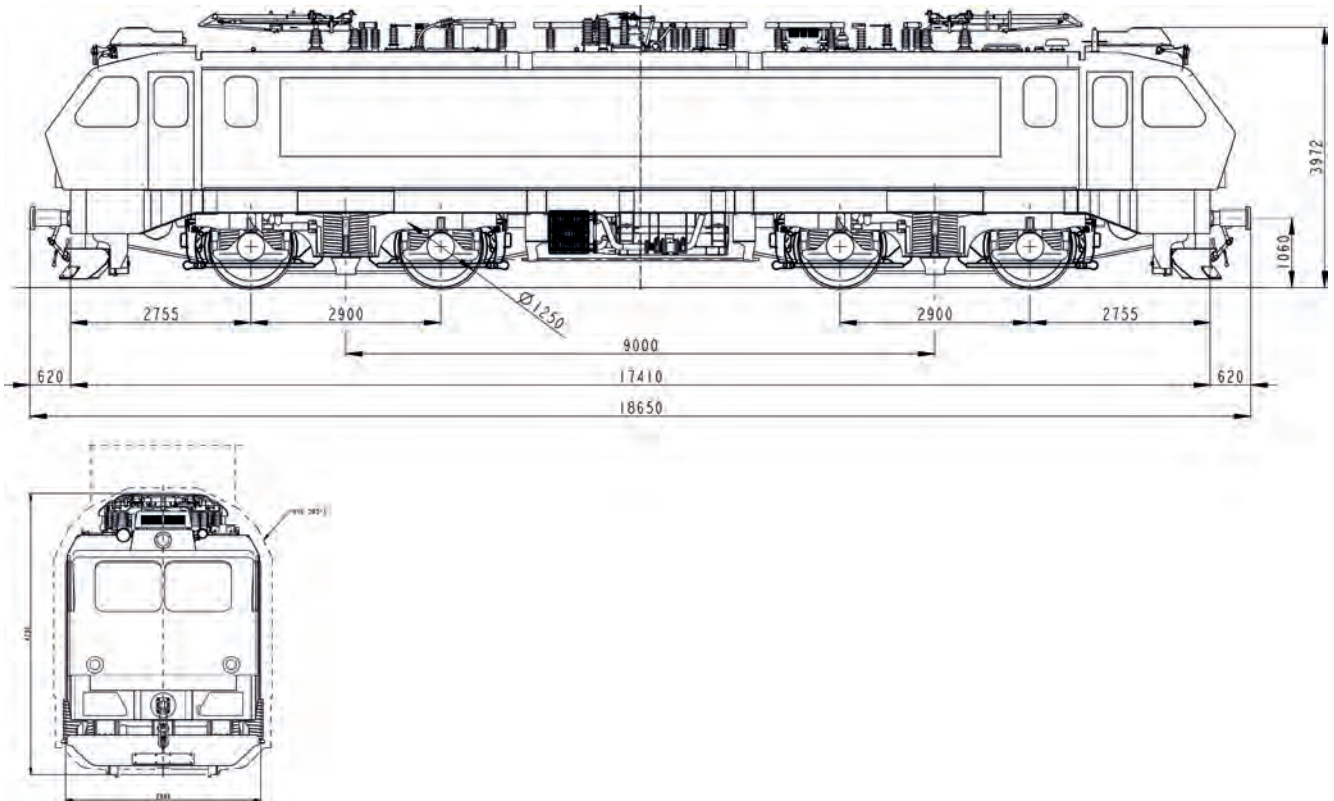

## LOCOMOTIVE MODEL DRAWING

## LOAD DIAGRAM

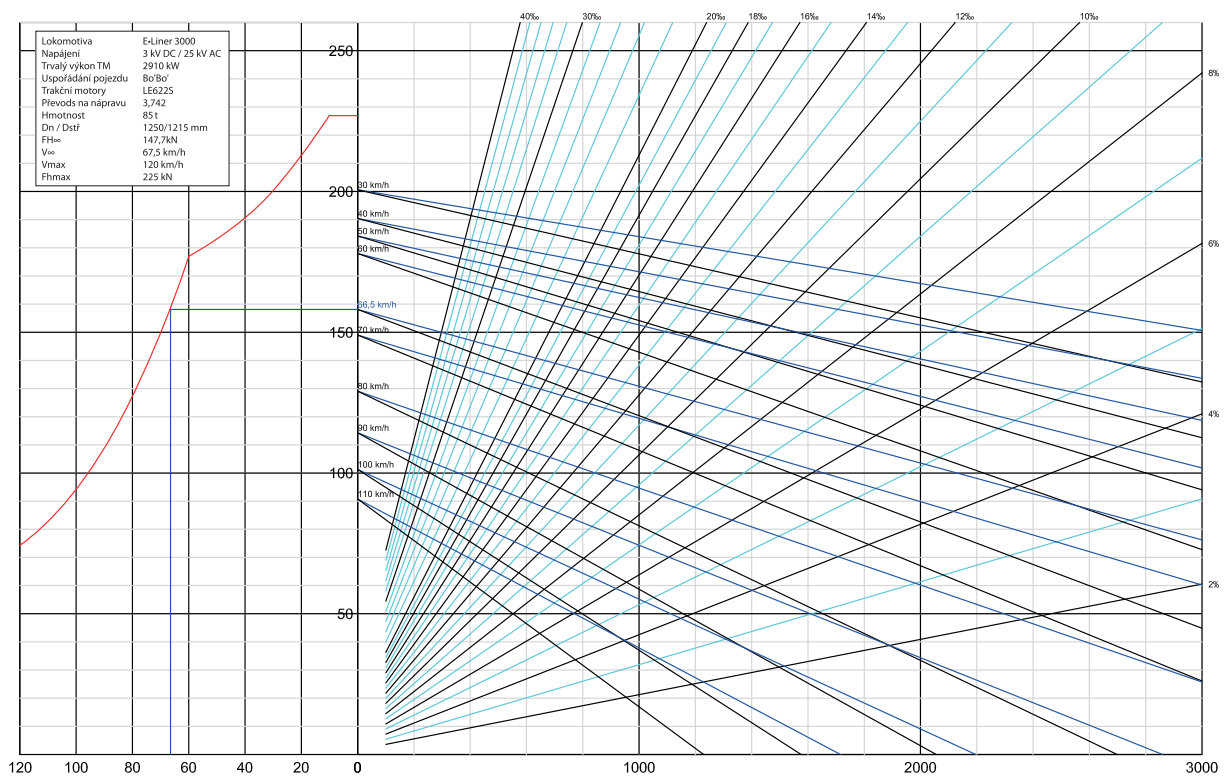

# 2M62UM

The two-piece diesel locomotive class **2M62UM** is designed as a cab unit type with one driver's cab in each section. The locomotive is equipped with alternating/direct current power transfer (AC/DC) from the diesel engine to six powered wheelsets in each of two sections. Parameters of the vehicle are optimized for line service.

## BENEFIT AND ADVANTAGES

- High reliability
- Low operating and maintenance costs
- Ecological operation
- Extended service intervals
- Modern concept and design
- Use of unified solutions
- High comfort and operator safety
- Excellent field of view



The undercarriage of each of two sections of the locomotive comprises two three-axle bogies with individual drive of all wheelsets. The traction motors are fitted to the axles using sliding axle-mounted bearings. The drive unit is located in the engine room and comprises an MTU diesel engine and a Lechmotoren traction alternator. In the engine room there are also auxiliary drives, a diesel engine cooling block, a pneumatic block and a switchboard with an electrodynamic brake block. The power regulation and control of the whole locomotive is ensured by a MSV elektronika control system with automatic speed control (ARR) function and remote diagnostics by means of GSM and GPS technologies. The locomotive is equipped with a DAKO air brake and a parking (hand) brake.

## PARAMETERS 2M62UM

Track gauge	1 520 mm
Meets the standards	EN
Number of powered axles	6
Wheelset arrangement	C'o C'o
Maximum operating speed	100 km/h
Minimum curve radius	125 m
Power transmission	electric AC/DC
Diesel engine	MTU 16V 4000 R43
EU Stage	IIIA
Engine output	2 200 kW
Maximum towing capacity	432 kN
Nominal weight	138 t
Axle load	23 t
Compressor output	318 m <sup>3</sup> /h
Fuel tank volume	7 100 l
Climate class	-40 to +40 °C

## EQUIPMENT

- Digital control system
- Automatic speed control (ASC)
- Remote monitoring via GSM and GPS technologies
- Multiple control
- Air drier
- Electro-dynamic brake (EDB)
- Wheel slip protection (at traction)
- Camera system

## OPTIONAL EQUIPMENT

- Anti-skid device (during braking)

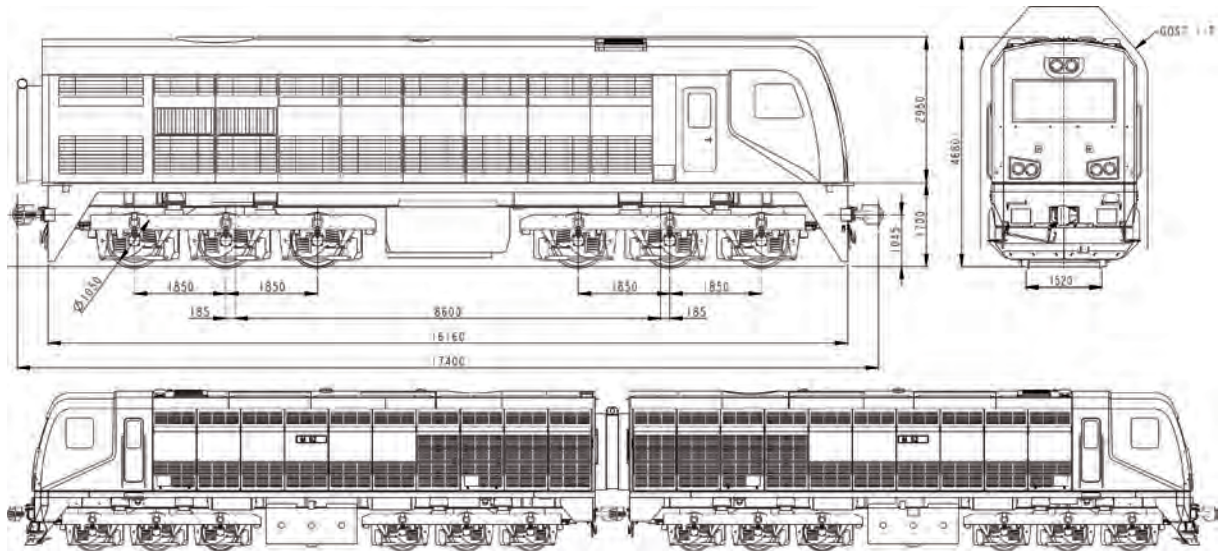

## LOCOMOTIVE MODEL DRAWING

## LOAD DIAGRAM

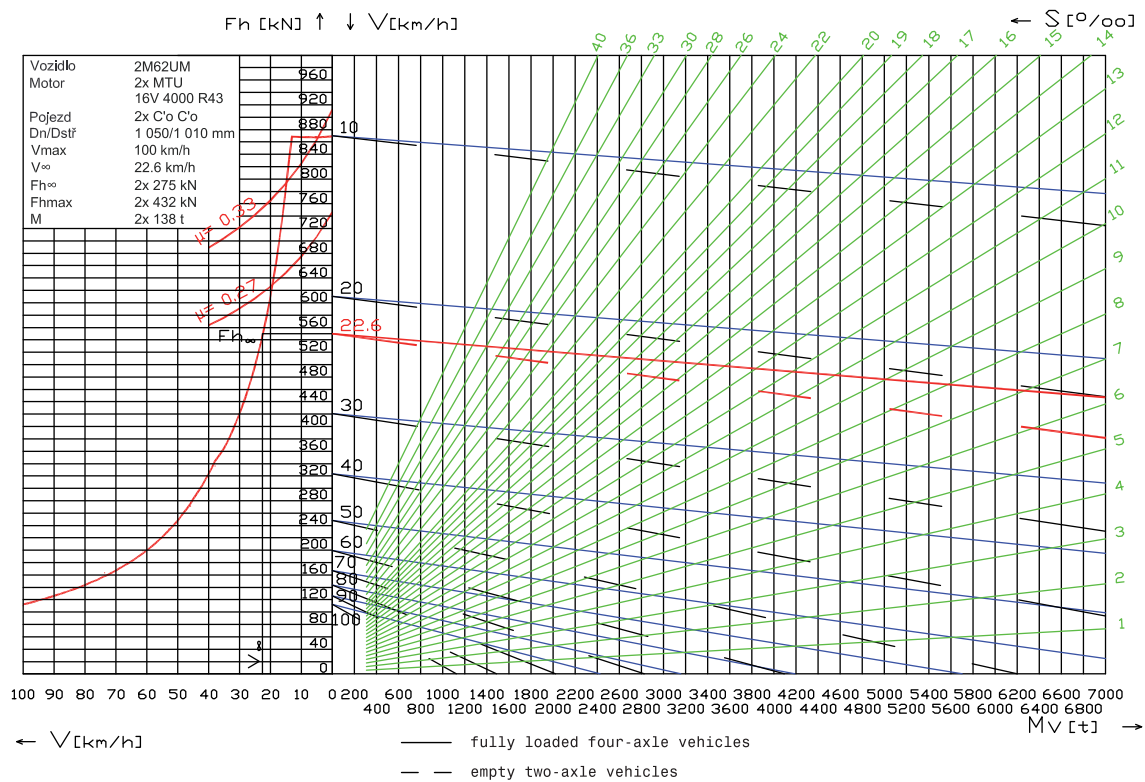

# MUV75

The universal motor truck **MUV 75** is designed for railway line maintenance. The vehicle is equipped with hydrostatic power transfer from the diesel engine to two powered wheelsets.



A two-axle undercarriage of the vehicle consists of a wheelset with the internal seating of axle bearings and suspension. There is an individual hydraulic motor for each wheelset. The drive unit is located behind the driver's cab and consists of the Caterpillar diesel engine and a hydraulic block of Parker components. Behind the drive unit there is a freight compartment with folding and removable sidewalls. Under the main frame there is a fuel tank, vehicle accumulators and a pneumatic block. Protective fender elements are installed on the front of the vehicle at buffer height. Spring-loaded couplers can be installed on the vehicle. Fixtures for transport of rails with various lengths are installed on the sides of the vehicle. The vehicle offers the speed mode for driving at 0 – 70 km/h and a working speed mode at 2 – 10 km/h. The vehicle is equipped with an air brake and a parking (stored-energy) brake.

## PARAMETERS MUV 75

Track gauge	1 435 mm
Meets the standards	EN
Number of powered axles	2
Wheelset arrangement	Bo
Maximum operating speed	75 km/h
Minimum curve radius	90 m
Power transmission	hydrostatic
Diesel engine	CAT C 4.4
EU Stage	IIIB
Engine output	130 kW
Maximum towing capacity	16 kN
Nominal weight	14,7t
Axle load	7,35t
Fuel tank volume	300 l
Weight of load	max. 5 t
Occupancy (seated persons)	1+6
Climate class	-25 to +40 °C

## BENEFIT AND ADVANTAGES

- High reliability
- Low operating and maintenance costs
- Ecological operation
- Modern concept and design
- Use of unified solutions
- High comfort and operator safety
- Excellent field of view
- Service interval: 1,000 km / 3 months



## EQUIPMENT

- Digital control system
- Cruise control
- Operating speed 2 to 10 km/h
- Air drier
- Stored-energy, spring-actuated parking brake
- Disc brake

## OPTIONAL EQUIPMENT

- Hydraulic loading crane with remote control
- Rotator, hook, grab, shovel dipper, drill, etc.
- Grass mower
- Sweeper for cleaning of platforms and other areas
- Snow blower
- Snow-plough
- Storage tank superstructure
- Mobile workshop:
- Trolley superstructure
- Vacuum cleaner
- Shredder
- Gravel sand plough
- GPK measuring system etc.

# MUV75

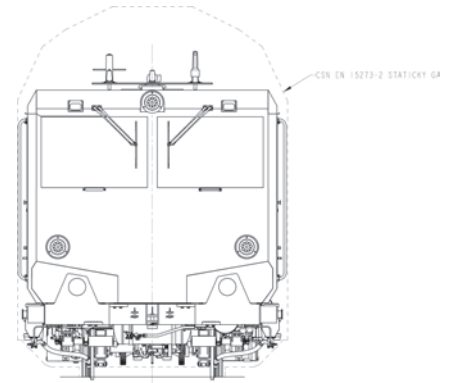
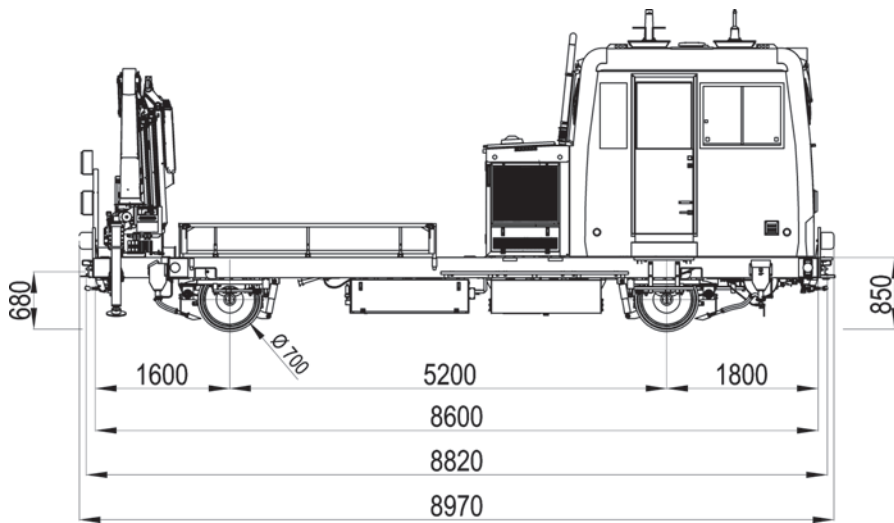

 **Metro Suitable**

## LOCOMOTIVE MODEL DRAWING



---

## SPECIAL PROJECTS



### MMD.1

---

measuring rail diesel car for diagnostics of railway track geometric parameters

### MUV74.2

---

with snowblower



### DJ NDT

---

unit for diagnostics of rail defects (defectoscopic inspection of rails using ultrasonic and eddy current methods)

### MV ETCS

---

track-measuring car for ETCS (European Train Control System) system diagnostics











**CZ LOKO**

*Locomotion Excellence®*

[www.czloko.cz](http://www.czloko.cz)

 [www.facebook.com/czloko](https://www.facebook.com/czloko)

**CZ LOKO, a.s.** | Semanínská 580 | 560 02 Česká Třebová | Czech Republic  
phone: +420 325 518 811 | e-mail: [czloko@czloko.cz](mailto:czloko@czloko.cz)